



Pneumatic Agitators for
Paint, Sealants, and Adhesive.

ROTARY AIR MOTORS BROCHURE



COSMOSTAR
— SINCE 1979 —



EXPERIENCE • QUALITY • CARE



SINCE 1979
COSMOSTAR



AGITATOR SERIES

COSMOSTAR Agitators guarantee painting quality by thoroughly mixing and better particle dispersion in your mix tank or throughout the whole painting system.

HOW TO ORDER YOUR AGITATOR:

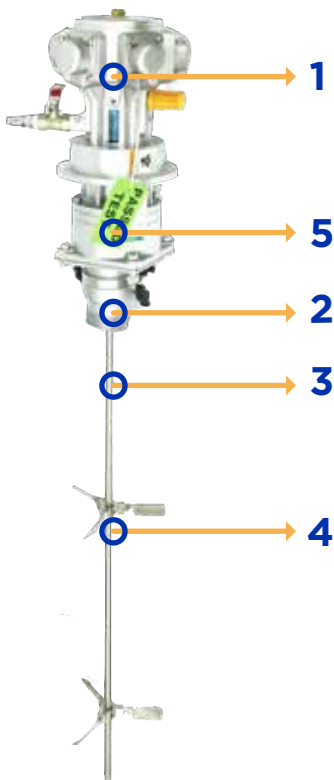

1. Choose AIR MOTOR TYPE (refer p.2)
2. Choose MOUNTING TYPE (refer p.3-10)
3. Choose SHAFT TYPE (refer p.11)
4. Choose PROPELLER TYPE (refer p.11-12)
5. Choose GEARBOX TYPE (refer p.12)

ORDERING EXAMPLE

Agitator equipped with:

- M0705 1/8HP Three piston type air motor
- Clamp mounted
- Carbon steel shaft 30.5cm length, 12mm diameter
- Gear propeller, SUS, 10cm
- Gear box 3:1



ROTARY AIR MOTOR



AM0701

Type	Max Output Power	Max Torque	Max Speed	Max Air Consumption	Weight
Vane type	0.9 HP	3.0 N/m	3000 RPM	750 L/min (6 Bar, 3000 RPM)	2.61 kg



AM0706

Type	Max Output Power	Max Torque	Max Speed	Max Air Consumption	Weight
Vane type	1.7 HP	6.3 N/m	3000 RPM	1800 L/min (6 Bar, 3000 RPM)	3.33 kg



AM0705

Type	Max Output Power	Max Torque	Max Speed	Max Air Consumption	Weight
Three Piston Type	1/8 HP	1.3 N/m	2500 RPM	270 L/min (6 Bar, 1750 RPM)	2 kg



AM0707

Type	Max Output Power	Max Torque	Max Speed	Max Air Consumption	Weight
Five Piston Type	1/2 HP	7.0 N/m	1700 RPM	600 L/min (6 Bar, 1000 RPM)	5 kg

AGITATOR MOUNTING VARIATIONS

▶ PORTABLE TYPE



▶ CLAMP-MOUNTED

Portable agitator set that allows to be clamped to the side of the drum.

MADE FOR CUSTOM SIZE DRUM



▶ U-SHAPE PAILS COVER

Portable agitator installed to adjustable drum cap.



▶ BUNG-MOUNTED

Portable agitator set with screw driven clamp to be mounted to the open head drum.



COMPACT SERIES

Portable agitator and transfer pump set to be mounted on open drum.



▶ U-SHAPE PAILS COVER

Portable agitator installed to adjustable drum cap.



▶ ROUND-SHAPE PAILS COVER

Portable agitator set installed to round-shape drum cap.



▶ SQUARE-SHAPE PAILS COVER

Portable agitator set installed to square-shape drum cap.

▶ STATION TYPE



▶ **MANUAL LIFT STAND**

Mixing station with adjustable lifting stand to fit to your drum size variety.



▶ **PORTABLE MOUNT, AIR LIFT STAND**

Fluid mixing station with air-control lifting stand and allows high mobility application.



▶ **PLATE MOUNT, AIR STAND**

Mixing station with air-control lifting stand to fit to your drum size variety.



▶ **FIXED DRUM MOUNT WITH MANUAL-LIFT STAND**

Fluid mixing station with adjustable lifting stand and fixed drum feature for stability during the mixing process.



▶ **PORTABLE MOUNT, AIR LIFT STAND WITH CONTROL BOX**

Equipped with control box to set mixing duration for automatic mixing.

CLAMP & BUNG MOUNTED

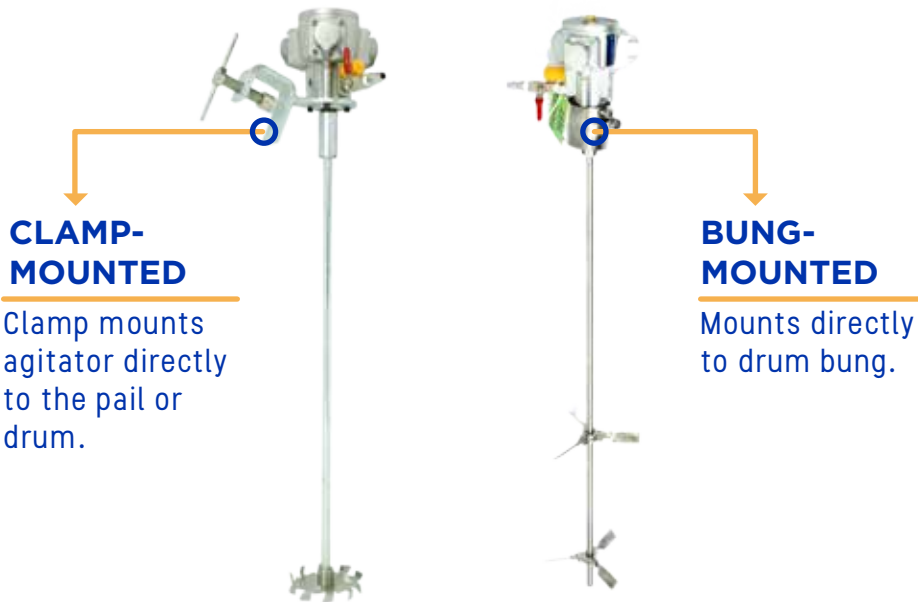

CLAMP-MOUNTED

Clamp mounts agitator directly to the pail or drum.

BUNG-MOUNTED

Mounts directly to drum bung.

ORDERING EXAMPLE: M0705-CM-CS20S12-G10S12

M0705 — **CM** — **CS** — **20** — **S12** — **G10**

Air Motor Model	Mounting Type		Shaft Material		Shaft Length		Shaft Diameter		Diameter		Material
0701	CM	Clamp	CS	Carbon Steel	20	30.5cm	S12	∅ 12mm	G5	5cm	SUS
0706	BM	Bung	SUS	Stainless Steel	40	46.5cm	S17	∅ 17mm	G7	7cm	SUS
0705					60	67cm			G10	10cm	SUS
0707					200	83cm			G14	14cm	SUS
									G17	17cm	SUS
									G20	20cm	SUS
									G25	25cm	SUS
									EX6	6 inch	SUS
									EX10	10 inch	SUS
									ES7	7cm	SUS
									ES10	10cm	SUS
									ES17	17cm	SUS
									ES325	32.5cm	SUS
									ES425	42.5cm	SUS
									EP10	10cm	Plastic
									EA10	10cm	Aluminium
									EA17	17cm	Aluminium
									ESS7	7cm	SUS
									ESS10	10cm	SUS
									ESS14	14cm	SUS

*For custom size please contact us

*For propeller detailed information refer to p.11-12

PAILS COVER AGITATOR



U-SHAPE COVER

- ▶ Agitator mounts directly to the pails or drum cover.
- ▶ Lift handles for easy moving and color changes.

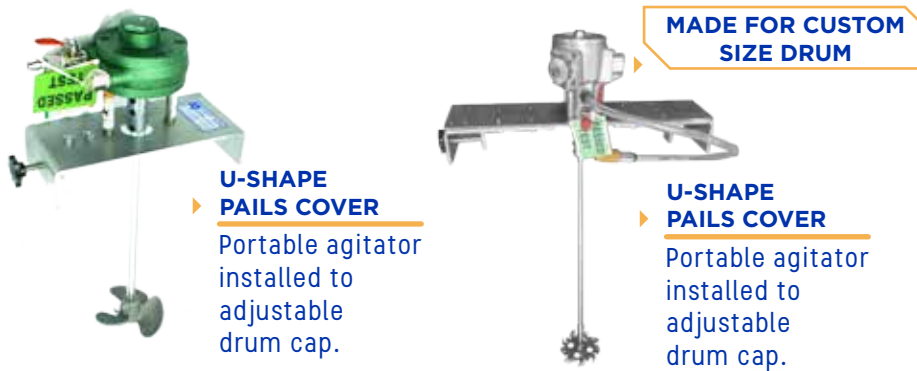

ORDERING EXAMPLE: M0705-UC-CS-20-S12-G10

M0705 — **UC** — **CS** — **20** — **S12** — **G10**

Air Motor Model	Mounting Type		Shaft Material		Shaft Length		Shaft Diameter		Diameter		Material
0701	UC	U Shape	CS	Carbon Steel	20	30.5cm	S12	∅ 12mm	G5	5cm	SUS
0706			SUS	Stainless Steel	40	46.5cm	S17	∅ 17mm	G7	7cm	SUS
0705					60	67cm			G10	10cm	SUS
0707					200	83cm			G14	14cm	SUS
									G17	17cm	SUS
									G20	20cm	SUS
									G25	25cm	SUS
									EX6	6 inch	SUS
									EX10	10 inch	SUS
									ES7	7cm	SUS
									ES10	10cm	SUS
									ES17	17cm	SUS
									ES325	32.5cm	SUS
									ES425	42.5cm	SUS
									EP10	10cm	Plastic
									EA10	10cm	Aluminium
									EA17	17cm	Aluminium
									ESS7	7cm	SUS
									ESS10	10cm	SUS
									ESS14	14cm	SUS

*For custom size please contact us

*For propeller detailed information refer to p.11-12



PAILS COVER

- ▶ Agitator mounts directly to the pails or drum cover.
- ▶ Lift handles for easy moving and color changes.



▶ **ROUND-SHAPE PAILS COVER**
 Portable agitator set installed to round-shape drum cap.



▶ **SQUARE-SHAPE PAILS COVER**
 Portable agitator set installed to square-shape drum cap.

ORDERING EXAMPLE: M0705-SC20-CS20S12-G10S12

M0705 — SC — 20 — CS — 20 — S12 — G10

Air Motor Model	Mounting Type		Cover Size		Shaft Material		Shaft Length		Shaft Diameter		Diameter		Material
0701	SC	Square Shape	20	23x23cm	CS	Carbon Steel	20	30.5cm	S12	∅12mm	G5	5cm	SUS
0706	RC	Round Shape	20	∅30.5cm	SUS	Stainless Steel	40	46.5cm	S17	∅17mm	G7	7cm	SUS
0705			40	∅35.5cm			60	67cm			G10	10cm	SUS
0707							200	83cm			G14	14cm	SUS
											G17	17cm	SUS
											G20	20cm	SUS
											G25	25cm	SUS
											EX6	6 inch	SUS
											EX10	10 inch	SUS
											ES7	7cm	SUS
											ES10	10cm	SUS
											ES17	17cm	SUS
											ES325	32.5cm	SUS
											ES425	42.5cm	SUS
											EP10	10cm	Plastic
											EA10	10cm	Aluminium
											EA17	17cm	Aluminium
											ESS7	7cm	SUS
											ESS10	10cm	SUS
											ESS14	14cm	SUS

*For custom size please contact us

*For propeller detailed information refer to p.11-12

MANUAL LIFT AGITATOR



- ▶ Safely and easily raise and lower the agitator.
- ▶ Stable mixing process with the fixed-drum mounted.



MANUAL LIFT STAND

Mixing station with adjustable lifting stand to fit to your drum size variety.



FIXED DRUM MOUNT WITH MANUAL-LIFT STAND

Fluid mixing station with adjustable lifting stand and fixed drum feature for stability during the mixing process.

ORDERING EXAMPLE: M0705-CM-CS20S12-G10S12

M0705 — ML — CS — 20 — S12 — G10

Air Motor Model	Mounting Type		Dimension	Shaft Material		Shaft Length		Shaft Diameter		Diameter		Material
0701	ML	Manual Lift	35x40x105cm	CS	Carbon Steel	20	30.5cm	S12	∅ 12mm	G5	5cm	SUS
0706	MLH1	Manual Lift	17x33x90cm	SUS	Stainless Steel	40	46.5cm	S17	∅ 17mm	G7	7cm	SUS
0705	MLH2	Manual Lift	17x33x60cm			60	67cm			G10	10cm	SUS
0707	FD	Fixed Drum	35x40x105cm			200	83cm			G14	14cm	SUS
	FD1	Fixed Drum	17x33x90cm	G17	17cm	SUS						
	FD2	Fixed Drum	17x33x60cm	G20	20cm	SUS						
				G25	25cm	SUS						
						EX6	6 inch	SUS				
						EX10	10 inch	SUS				
						ES7	7cm	SUS				
						ES10	10cm	SUS				
						ES17	17cm	SUS				
						ES325	32.5cm	SUS				
						ES425	42.5cm	SUS				
						EP10	10cm	Plastic				
						EA10	10cm	Aluminium				
						EA17	17cm	Aluminium				
						ESS7	7cm	SUS				
						ESS10	10cm	SUS				
						ESS14	14cm	SUS				

*For custom size please contact us

*For propeller detailed information refer to p.11-12

AUTOMATIC LIFT AGITATOR

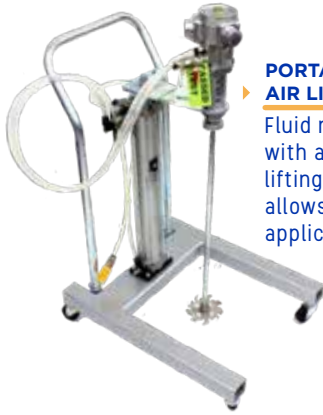

**PORTABLE MOUNT,
AIR LIFT STAND**

Fluid mixing station with air-control lifting stand and allows high mobility application.



**PORTABLE MOUNT,
AIR LIFT STAND
WITH CONTROL BOX**

Equipped with control box to set mixing duration for automatic mixing.



**PLATE MOUNT,
AIR STAND**

Mixing station with air-control lifting stand to fit to your drum size variety.

ORDERING EXAMPLE: M0705-AL-CS20S12-G10S12

M0705 — AL — CS — 20 — S12 — G10

Air Motor Model	Mounting Type		Shaft Material		Shaft Length		Shaft Diameter		Diameter		Material
0701	AL	Air Lift Cart	CS	Carbon Steel	20	65cm (max. drum height 35cm)	S12	∅ 12mm	G5	5cm	SUS
0706	ALP	Air Lift Plate	SUS	Stainless Steel			S17	∅ 17mm	G7	7cm	SUS
0705					60	89cm (max. drum height 60cm)			G10	10cm	SUS
0707									G14	14cm	SUS
									G17	17cm	SUS
									G20	20cm	SUS
									G25	25cm	SUS
									EX6	6 inch	SUS
									EX10	10 inch	SUS
									ES7	7cm	SUS
									ES10	10cm	SUS
									ES17	17cm	SUS
									ES325	32.5cm	SUS
									ES425	42.5cm	SUS
									EP10	10cm	Plastic
									EA10	10cm	Aluminium
									EA17	17cm	Aluminium
									ESS7	7cm	SUS
									ESS10	10cm	SUS
									ESS14	14cm	SUS

*For custom size please contact us

*For propeller detailed information refer to p.11-12



COMPACT SERIES



▶ Portable agitator and transfer pump set to be mounted on open drum.

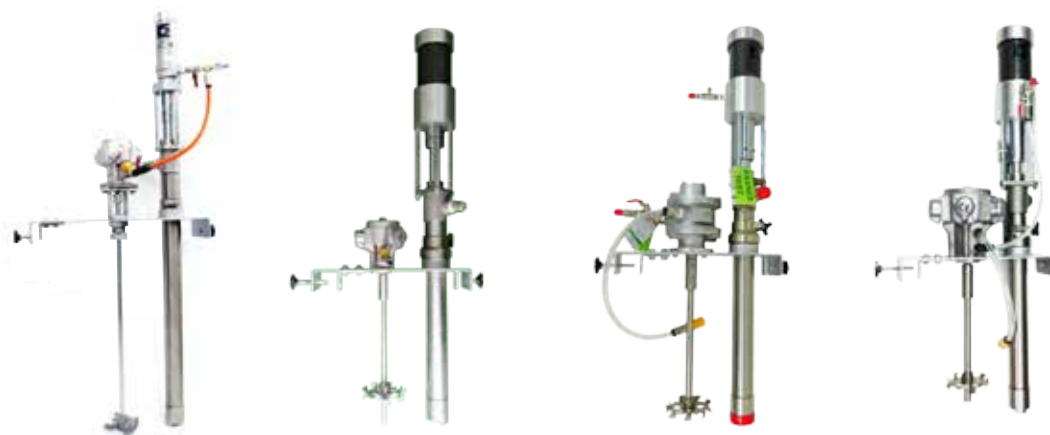

ORDERING EXAMPLE: P0201SB-AM0705-UC-SUS20-S12-EA10

P0201SB — AM0705 — UC — SUS — 20 — S12 — EA10

Transfer Pump Model	Pressure Ratio	Drum Size	Air Motor Model	Mounting Type		Shaft Material		Shaft Length		Shaft Diameter		Diameter	Material	
P0201SA	1:1	20L	0701	UC	U Shape	CS	Carbon Steel	20	For 20L drum	S12	ø12mm	G5	5cm	SUS
P0201SB	1:1	20L	0706			SUS	Stainless Steel	200	For 200L drum	S17	ø17mm	G7	7cm	SUS
P0204SA	2:1	200L	0705			G10	10cm	SUS						
P0204SB	2:1	200L	0707			G14	14cm	SUS						
												G17	17cm	SUS
												G20	20cm	SUS
												G25	25cm	SUS
												EX6	6 inch	SUS
												EX10	10 inch	SUS
												ES7	7cm	SUS
												ES10	10cm	SUS
												ES17	17cm	SUS
												ES325	32.5cm	SUS
												ES425	42.5cm	SUS
												EP10	10cm	Plastic
												EA10	10cm	Aluminium
												EA17	17cm	Aluminium
												ESS7	7cm	SUS
												ESS10	10cm	SUS
												ESS14	14cm	SUS

*For custom size please contact us

*For propeller detailed information refer to p.11-12

*For compact series with different air motor, shaft length, propeller and transfer pump please contact us

SHAFT TYPE



CS — L36 — S12					SS — L36 — S12				
Shaft Material		Shaft Length		Shaft Diameter	Shaft Material		Shaft Length		Shaft Diameter
Carbon Steel	L36	36cm	S12	12mm	Stainless Steel	L36	36cm	S12	12mm

Shaft Length	Shaft Diameter	Carbon Steel Part No.	Stainless Steel Part No.
30.5cm	12mm	CS20S12	SUS20S12
36cm	12mm	CSL36S12	SSL36S12
40cm	12mm	CSL40S12	SSL40S12
46.5cm	12mm	CS20S12	SUS40S12
49cm	12mm	CSL49S12	SSL49S12
67cm	12mm	CS60S12	SUS60S12
83cm	12mm	CS200S12	SUS200S12
87cm	12mm	CSL87S12	SSL87S12
76cm	17mm	CSL76S17	SSL76S17
87cm	17mm	CSL87S17	SSL87S17

*For custom length please contact us

PROPELLER



THREE-BLADE

▶ MATERIAL: PLASTIC



PN	Diameter	Shaft Diameter
EP10S12	10cm	12mm

▶ MATERIAL: ALUMINIUM



PN	Diameter	Shaft Diameter
EA10S12	10cm	12mm
EA17S12	17cm	12mm
EA17S17	17cm	17mm

▶ MATERIAL: SUS



PN	Diameter	Shaft Diameter
ESS7S12	7cm	12mm
ESS7S17	7cm	17mm
ESS10S12	10cm	12mm
ESS10S17	10cm	17mm
ESS14S12	14cm	12mm
ESS14S17	14cm	17mm

PROPELLER



GEAR

▶ MATERIAL: SUS



PN	Diameter	Shaft Diameter
G5S12	5cm	12mm
G7S12	7cm	12mm
G10S12	10cm	12mm
G10S17	10cm	17mm
G14S12	14cm	12mm
G14S17	14cm	17mm
G17S12	17cm	12mm
G17S17	17cm	12mm
G20S17	20cm	17mm
G25S17	25cm	17mm

EXPANDABLE

▶ MATERIAL: SUS



PN	Diameter	Shaft Diameter
EX6S12	6inch	12mm
EX6S17	6 inch	17mm
EX10S12	10 inch	12mm
EX10S17	10 inch	17mm

TWO-BLADE

▶ MATERIAL: SUS



PN	Diameter	Shaft Diameter
ES7S12	7cm	12mm
ES7S17	7cm	17mm
ES10S12	10cm	12mm
ES10S17	10cm	17mm
ES17S12	17cm	12mm
ES17S17	17cm	17mm
ES325S17	32.5cm	17mm
ES425S17	42.5cm	17mm

GEAR BOX



PN	Ratio
GB3	3:1
GB5	5:1
GB10	10:1
GB20	20:1



BEST QUALITY PRODUCTS



ABOUT COSMOSTAR

EXPERIENCE • QUALITY • CARE

Established in 1978, COSMOSTAR TECH LTD. has been a front runner among fluid handling equipment manufacturers in Taiwan. The key to our long success is exceptional experience, technical excellence, and dependable customer service. Having obtained EN-ISO 9001:2008 certification, we maintain our high quality control through world class management.

Our products cover various areas of fluid handling applications including spray finishing, fluid agitating, sealant, lubrication, adhesives, and large scale power application equipment for the contractor industry.

DISTRIBUTOR LOCATIONS

ASIA HEADQUARTER

COSMOSTAR TECH LTD.
No.8, Alley 6, Lane 15, Sec.2, Jiayuan Rd.,
Shulin District, New Taipei City 238, Taiwan
Tel: +886-2-28867799
Fax: +886-2-28868991
sales@cosmostar.net | www.cosmostar.net

EUROPE HEADQUARTER

TBH POLSKA SP.Z.O.O
ul. Bukowska 14, 62-080 Sieroslaw, Poland
Tel: +48 61 8963 615
Fax: +48 61 8963 900
sales@cosmo-star.com | www.cosmo-star.com

CHINA HEADQUARTER

上海菱山工业科技有限公司
12c No.3 99 Lane Cao Xi Bei Lu, Xu Jia Hui
Xuhui Qu, Shanghai, China
Tel: +86 15900615657

THAILAND

V-SPRAYS CO., LTD
307 Pattanakarn Rd., Praves 10250
Bangkok, Thailand
Tel: +66-2-7222115/116
Fax: +66-2-7224091
www.vthaispray.com

PHILIPPINES

MEGATECH FILFOR CORP.
Sta. Maria Drive cor. Sta. Teresita Drive, Sta.
Maria Industrial Subd.
Bagumbayan, Taguig City, Metro Manila, Philippines
Tel: +63-2-8387587
Fax: +63-2-8387587
sales@megatech-trading.com
www.megatech-trading.com

CHINA

RMS MARINE SERVICE COMPANY LTD
No. 365, Gaodong 2nd Rd., Shanghai, China, 200137
Tel: +86 21 50171617
Fax: +86 21 65380899
A.O.H.: +86 13122838027
www.rmsmarineservice.com

INDONESIA

COSMOSTAR INDONESIA – Surabaya
Jl. Margomulyo Permai D-28
Surabaya, East Java, 60183, Indonesia
Tel: +62-31-7494278
Fax: +62-31-7494279

PT.NORITA FLEXINDO – Jakarta

Jl. Puri Cileungsi No.27, Desa Gandoang,
Kabupaten Bogor, West Java, 16820, Indonesia
Tel: +62 21 824060770
Fax: +62 21 824060732
info@flexindo.net | www.flexindo.net

CV. WARNA ABADI PRATAMA – Surabaya

Jl. Darmo Baru Barat No. 32
Surabaya, East Java, 60189, Indonesia
Tel: +62-31-7346178
Fax: +62-31-7990139

SINGAPORE

Painttechnik Pte Ltd
27, Mandai Estate
#01-01 Innovation Place, Singapore, 729931
Tel: +65 6505 9088
chris.charlton@painttechnik.com

JAPAN

TUFF KOTE JAPAN, INC
Kanagawa-ken, Yokobamashi, Tsuzuki-ku
Orimoto-cho, 331, Japan, 224-0043
Tel: +81 45 472 2712
Fax: +81 45 472 2711
info@tuff-kote.co.jp | www.tuff-kote.co.jp

SOUTH AFRICA

BLASTRITE [PTY] LTD
16th Floor No.2 Long Street, Cape Town,
South Africa
Tel: +2721 417 1700
Fax: +2721 425 2486
www.blastrite.com

CONTACT US

CALL OUR CUSTOMER SERVICES TODAY FOR PRODUCTS INFORMATION OR TO REQUEST
A DEMONSTRATION INQUIRY.

+886-2-2688-7799 AND VISIT OUR WEBSITE AT WWW.COSMOSTAR.NET